

Engraving a Rosette

The hand engraver often faces situations where a circular area must be filled with fine engraving. While the finished piece looks impossibly complicated, the following steps will show you how to lay out and engrave this beautiful flower-like design which can be used in a variety of jewelry and gun engraving applications. I would also encourage you to be creative and invent your own designs using this as a model. Add and change petals or their shapes, and try different shading techniques. There are endless combinations you can use.

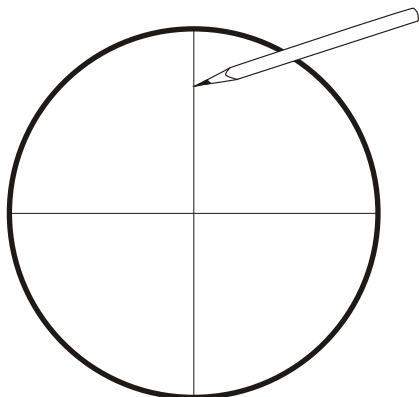

1.) A circle is drawn and engraved, then divided into quarters with a pencil.

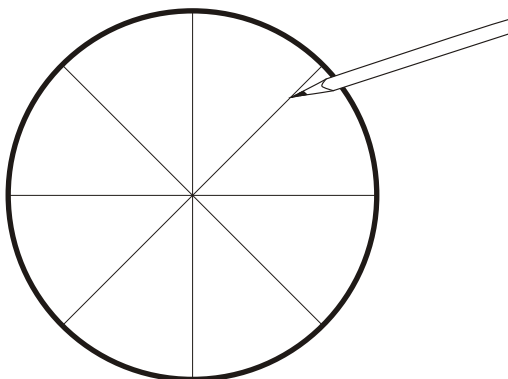

2.) The circle is then divided into eighths.

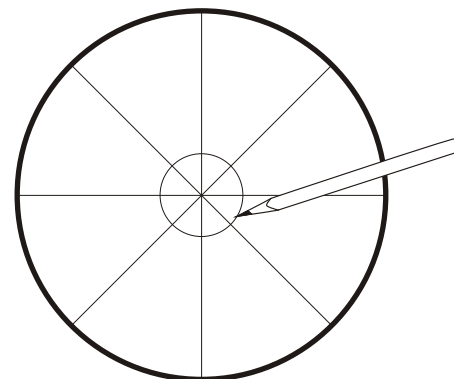

3.) A small center circle is added.

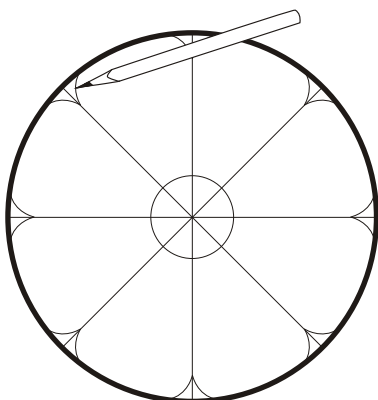

4.) Small, curved lines are sketched in to create flower

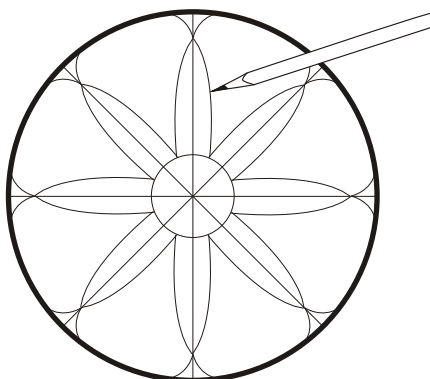

5.) Now add another layer of petals, using the layout lines in step 2 as guides to maintain symmetry.

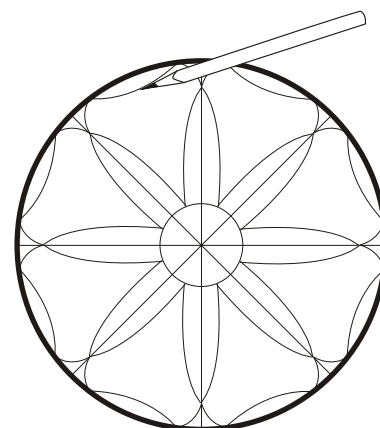

6.) Draw a curved line on each outer petal. This will be bright cut, with the graver tilted toward the inside of the flower, providing a sculpted look.

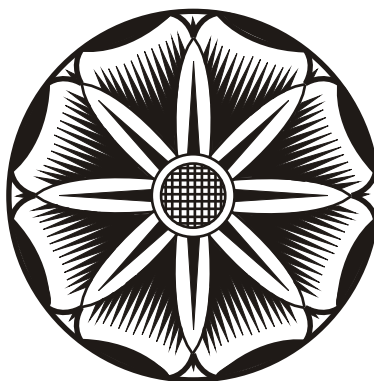

7.) An additional border is engraved inside the center circle, and the center is then crosshatched. The second layer of petals (step 2) receive a single, broad shading line down the center, and the outer petals come to life with multiple line shading. Finally, a single cut is made in the arc between each outer petal.